

# SANCOM

**SA-PAN019021-P47****1.9-2.1 GHz High Power GaN-HEMT**

## Features

Frequency Range: 1.9-2.1 GHz

$P_{\text{sat}}$ :  $\geq 47$  dBm

Power Gain:  $\geq 14$  dB

Efficiency:  $\geq 50\%$  (Type)

$Z_{\text{in}}/Z_{\text{out}} = 50 \Omega$



## Description

Sancom Electric's GaN-HEMT SA-PAN019021-P47 offers high power, high efficiency, ease of matching and greater consistency for high power applications with 28V operation. The SA-PAN019021-P47 typically provides 47 dBm of saturated output power and 14 dB of large-signal gain and can be widely used in various RF/microwave systems.

### ABSOLUTE MAXIMUM RATINGS

Parameter	Symbol	Condition	Rating	Unit
Drain-Source Voltage	$V_{DS}$	$TC=25^{\circ}C$	40	V
Gate-Source Voltage	$V_{GS}$	$TC=25^{\circ}C$	-5	V
Storage Temperature	$T_{stg}$	$TC=25^{\circ}C$	-65 to 150	$^{\circ}C$
Channel Temperature	$T_{ch}$	$TC=25^{\circ}C$	150	$^{\circ}C$

### ELECTRICAL SPECIFICATIONS

Parameter	Symbol	Condition	Min	Typ	Max	Unit
Drain-Source Current	$I_{DS}$	$V_{DS}: 28V$ CW (Continuous Wave) $P_{in}: 33 dBm$ Freq: 1.9 ~ 2.1 GHz	-	3.6	-	A
Saturated Power	$P_{sat}$		47	-	-	dBm
Power Gain	$G_p$		14	-	-	dB
Efficiency	$\eta$		50	-	-	%
Flatness	$\Delta G$		-0.8	-	0.8	dB

## Performance Plots

### Saturated Power VS Frequency

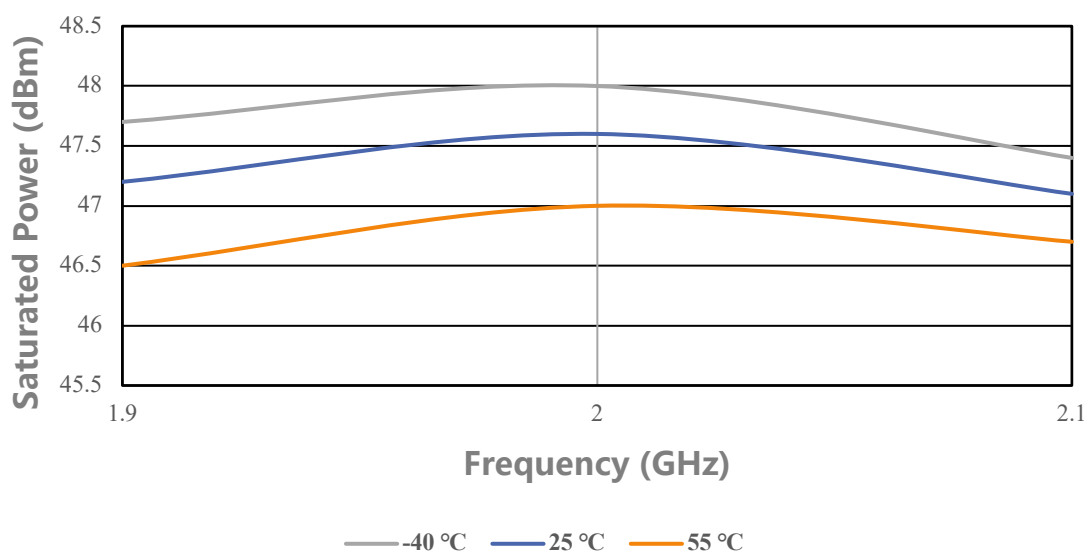

### Efficiency VS Frequency

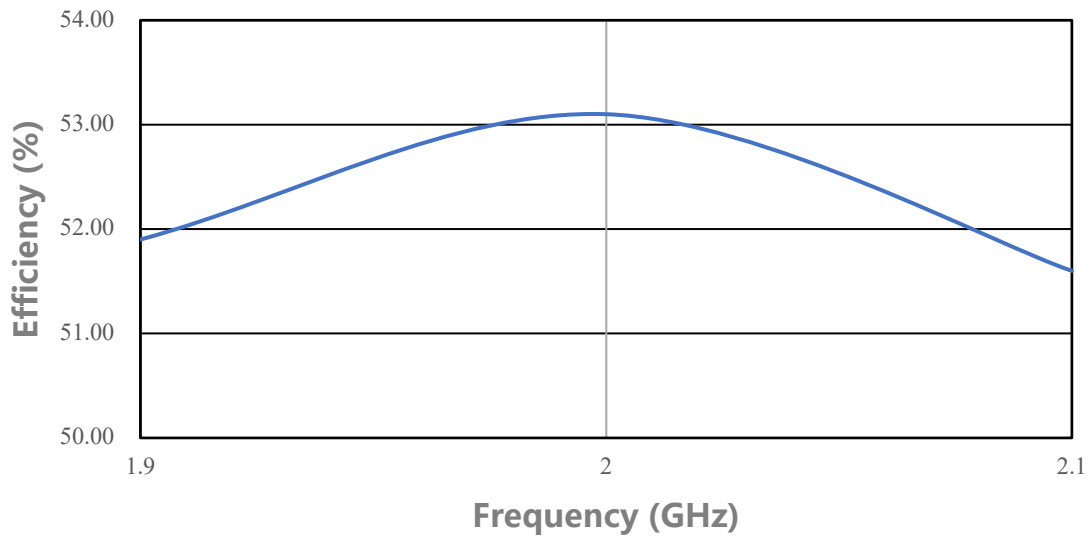

### Power Gain VS Frequency

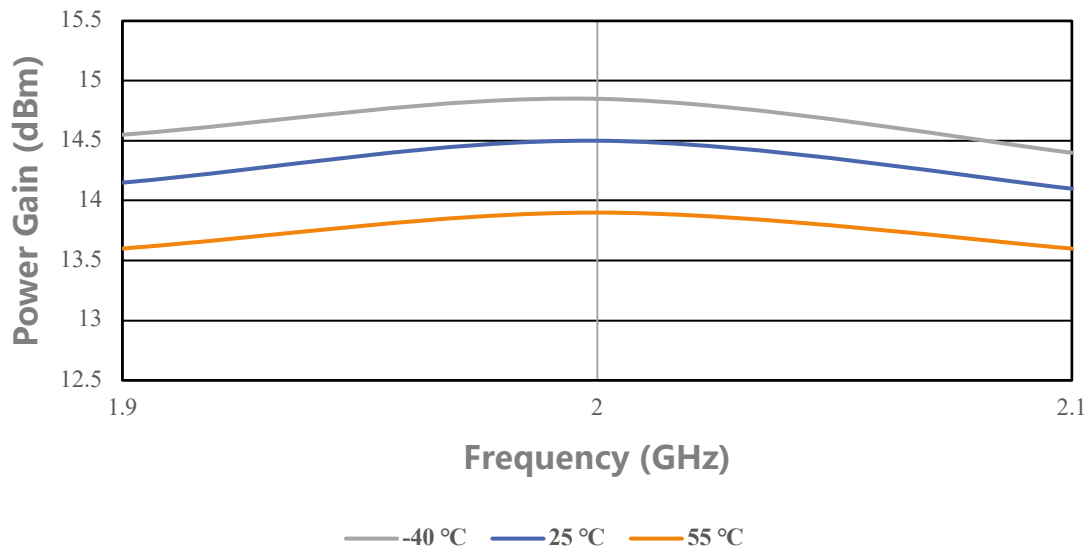

## Simplified Block Diagram

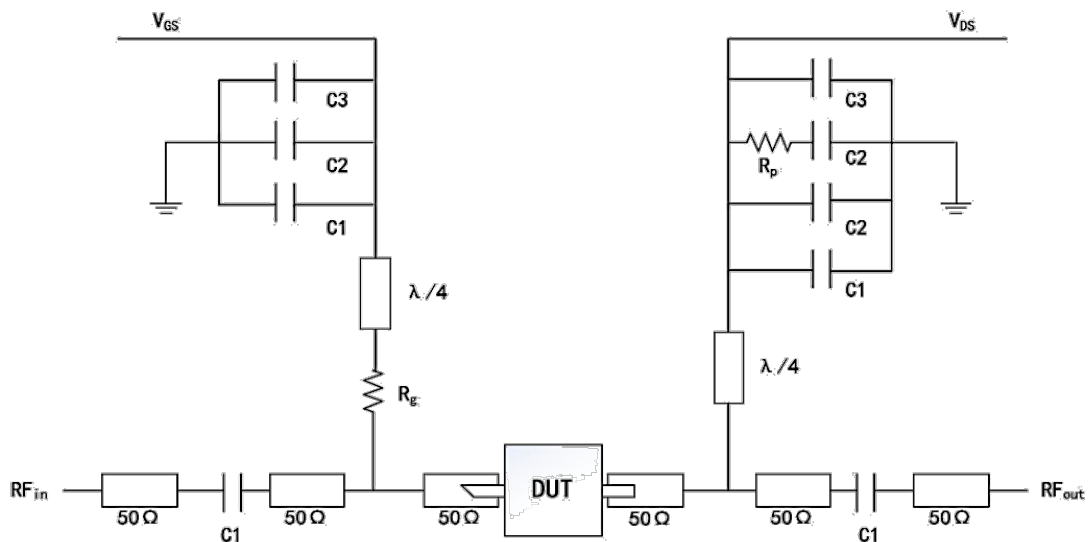

DUT information	
C1: 8 pF	Rp: 51 Ω
C2: 1000 pF	Rg: 15 Ω
C3: 100 μF	

## ESD Protection

ESD	Class III	2000 V
-----	-----------	--------

## Outline Drawing

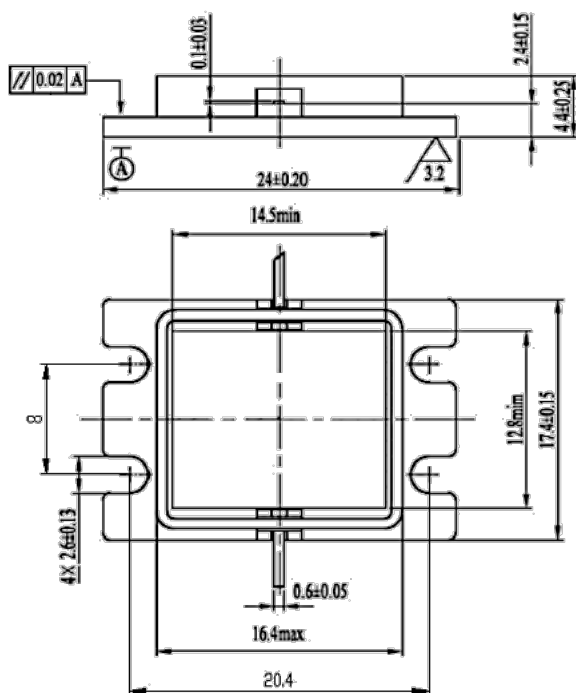

Unit: mm

## Attention

- Please keep away from moisture during transportation and storage
- Pay attention to ESD prevention during chip use and assembly. Wear a grounding ESD bracelet.
- When adding electricity, add gate electricity first and then add leakage electricity